

J. A. DeBRAME.  
Revolver.

No. 1,681. }  
No. 32,685. }

Patented July 2, 1861.

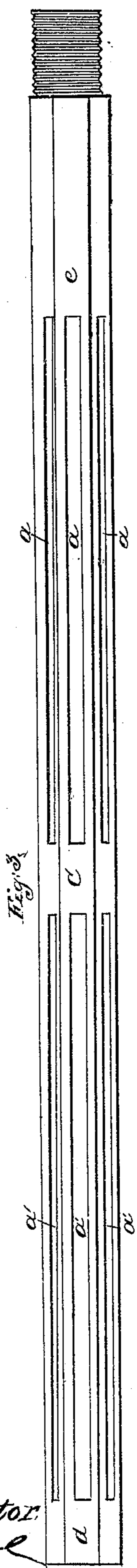
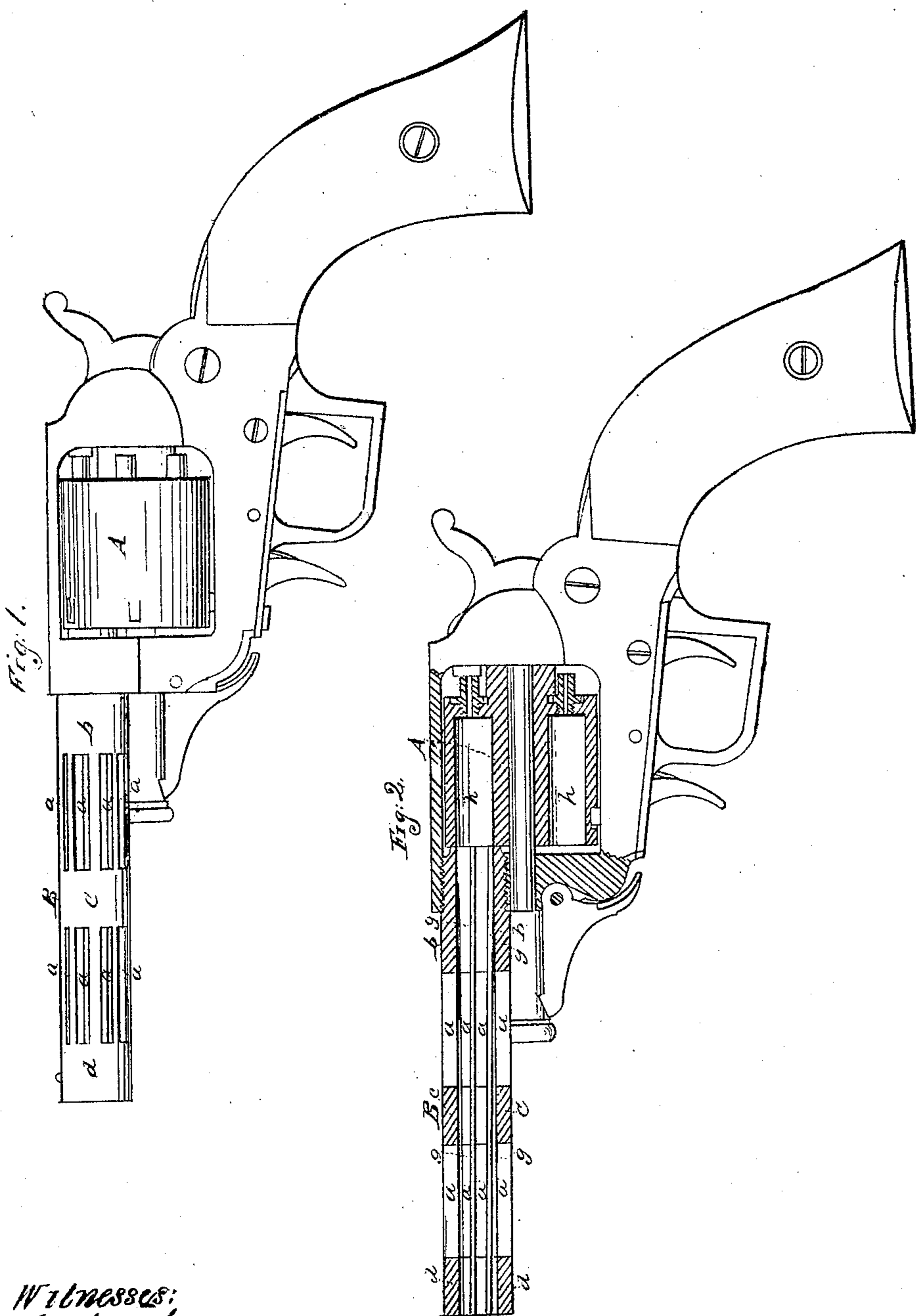

Witnesses:  
J. W. Coombs  
C. S. Spencer

Inventor:  
J. A. DeBrame

# UNITED STATES PATENT OFFICE.

J. A. DE BRAME, OF NEW YORK, N. Y.

## IMPROVEMENT IN FIRE-ARMS.

Specification forming part of Letters Patent No. 32,685, dated July 2, 1861.

*To all whom it may concern:*

Be it known that I, J. A. DE BRAME, of the city, county, and State of New York, have invented a new and useful Improvement in Ordnance and other Fire-Arms; and I do hereby declare that the following is a full, clear, and exact description of the same, reference being had to the accompanying drawings, forming a part of this specification, in which—

Figure 1 is a side view of a revolving pistol constructed according to my invention. Fig. 2 exhibits a central section of the revolving chambered breech and fixed barrel of the same. Fig. 3 is a longitudinal view, exhibiting the application of the invention to a fixed rifle-barrel.

Similar letters of reference indicate corresponding parts in the several figures.

My invention consists in what I term a "skeleton-barrel"—that is to say, in the construction of the barrel of a piece of ordnance or fire-arm with a portion of its length commencing at any distance in front of the chamber and extending to within any distance from the muzzle, with a series of openings extending in a longitudinal direction, or, in the case of rifled barrels, in a spiral direction corresponding with the rifling, leaving only metal enough to guide the projectile, by which construction the projectile is caused to be projected from the barrel with greater force and a greater distance with a moderate charge of powder than from a barrel of ordinary construction.

In applying my invention to ordnance and fire-arms with revolving or otherwise movable chambers and stationary barrels, I construct the chambers in the usual manner, and make the stationary barrels only, or a portion of the same, of the skeleton construction, as illustrated by Figs. 1 and 2. In these figures, A represents the chambered breech, and *h h* the chambers. B is the stationary barrel, represented as having nearly its whole length of skeleton construction, the openings being arranged in two series, *a a* and *a' a'*, of nearly equal length, those of each series being at equal distances apart all round the barrel, and the barrel being left whole for some distance from the chamber, as shown at *b*, between the two series of openings, as shown at *c*, and at the

muzzle, as shown at *d*. The same construction may be adapted to ordnance and fire-arms with movable chambers otherwise applied.

In applying my invention to ordnance and fire-arms with fixed chambers forming portions of the barrel or otherwise the same arrangement of openings in two series, *a a* and *a' a'*, may be adopted, the first series, *a a*, commencing a short distance in front of the chamber *e* and extending nearly half-way to the muzzle *d*, and the next series, *a' a'*, commencing a short distance in front of them and extending nearly to the muzzle, and a small portion of the length of the barrel between the two series being left whole, as shown at *c*; but with either construction of the chamber or chambers the openings may be constructed in a single series or in more than two series, according to the length of the barrel, or as may be required to give the barrel the requisite strength.

In adapting the invention to ordnance and fire-arms with rifled bores the openings *a a a' a'* may be of the same width as and coincide with the rifle-grooves, so that the lands *g g* (see Fig. 2) of the bore are continuous throughout the whole length of the barrel.

Instead of cutting the openings in the barrel from the solid metal, the barrel may, with the exception of the chamber and as much of it in front of the chamber as it is desired to have solid, be composed of a series of wires, rods, or bars, bound together at certain intervals with rings or bands, and the said wires, rods, or bars may be arranged spirally, to constitute the equivalents of a rifle-bore and cause the projectile to derive a rotary motion from its passage through or between them. It is not asserted that the perforating or slotting of the barrel will cause the ball to be projected with greater force in all cases where a sufficiency of powder is used to continue in active combustion until the ball reaches the muzzle of the closed barrel; but by carefully-conducted experiments with otherwise perfectly similar barrels, one whole and the other of skeleton form, and with the same barrel before and after cutting openings in it to make it of skeleton form, I have ascertained beyond doubt that from the barrel of skeleton form a ball is projected with far greater force and with equal

accuracy. This I believe results partly from the prevention of a less pressure of gas occurring within the barrel behind the projectile as compared with the pressure of air in front before it leaves the barrel, and partly from the reduction of the friction between the ball and the bore.

The invention is of special utility in arms in which any other power than the expansive force of gas is employed for projecting bullets or other missiles.

What I claim as my invention, and desire to secure by Letters Patent, is—

1. The construction of any portion of the

length of the barrel of a piece of ordnance or fire-arm of skeleton form, substantially as herein specified.

2. The combination, in a piece of ordnance or fire-arm with a movable chambered breech, of a chamber or chambers of ordinary construction—that is to say, without openings in the sides—and a stationary barrel of skeleton form, substantially as herein specified.

J. A. DE BRAME.

Witnesses:

HENRY T. BROWN,  
J. W. COOMBS.